

Instruction Manual (For Overseas)

TYPE : SPH(S)

Lápre
Shampoo Steamer AT



Table of Contents

Before reading this manual	1
1. Safety information	1
2. Packaged items	2
3. Read this before use	2
4. Name of each parts and function	3
5. Preparation for usage	5
6. Steam usage procedures	8
7. Shutting down the machine	10
8. Maintenance and inspection	12
9. Troubleshooting	16
10. Specification	17



Before reading this manual

- We thank you for choosing Lapre Shampoo Steamer AT (Type:SPH(S)). Please carefully read all the contents and please deeply understand how to use of this manual for safety use.
- SAVE THIS MANUAL FOR FUTURE REFERENCE.
- This machine requires periodical inspections and maintenances to achieve longer lifetime. Please observe the notes and run periodical maintenances written under this manual.
- We are not liable to all the damage, failure, and any loss of your remodeling, misusages, and other unauthorized handing/ usage of you.
- If you lost this manual, or should you have any question, please contact your dealer.
- Please note that the contents of instruction manuals will change due to product update without any note.

1. Safety information

To avoid any loss, harm, and danger to you, your family, and anyone around you, please read information very carefully. When using electrical appliances, basic safety precautions should be followed, including the following.

IMPOTANT SAFETY INSTRUCTIONS

 DANGER	DANGER - Immediate hazards which will result in severe personal injury, death or fire.
 WARNING	WARNING - Hazards or unsafe usage which could result in severe personal injury, damage, or loss.
 CAUTION	CAUTION - Hazards or dangerous practices which could result in minor personal injury besides those above.

+Neither the manufacturer of this machine nor the dealer can accept any liability for damage to the product or personal injury resulting from failure to use this product.

◆ WARNING LABELS applied as shown in the below picture.

In addition to this manual, there are WARNING, REQUEST and HIGH TEMPERATURE CAUTION labels on the body of this product. If the label is off, or hard to read because of scratch or damage, please contact your dealer.

① WARNING label For Drain Lever

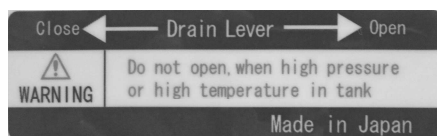

② REQUEST label

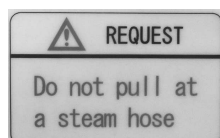

③ HIGH TEMPERATURE CAUTION label (2pcs)

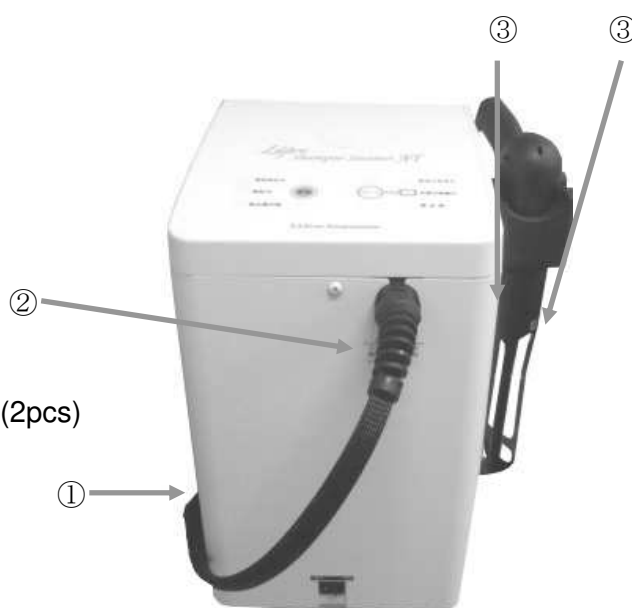

2. Packaged items

Packaged items besides the machine are followed. Please check when open the package.

Name	Instruction manual	Soft water cartridge	Water bottle	Nozzle holder	
Qty.	1pc	1pc	1pc	1 pc	
Shape					

3. Read this before use

Prior to the shipment, we carefully check this product, and you can use this machine as soon as you open the package. However, please carefully check if there is any damage (for example the damage during shipment) on the product before use. If you see any abnormal appearance, please contact your dealer.

4. Name of each parts and functions

Main Body

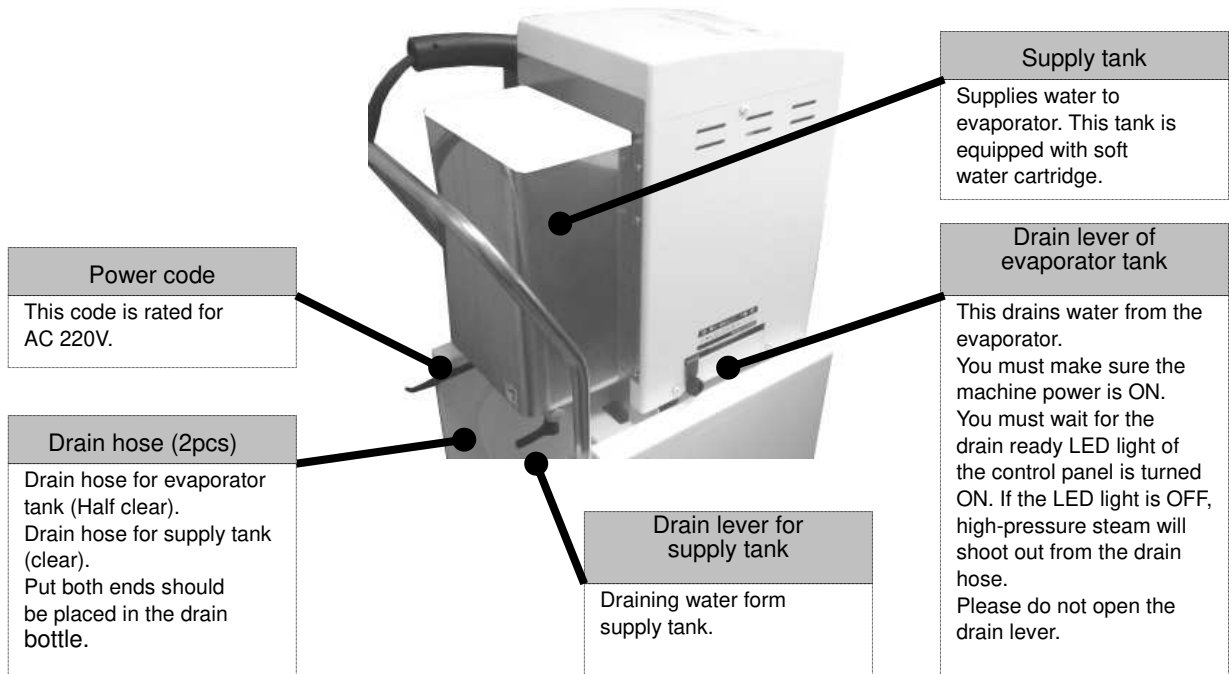

* Machine fall detector is equipped on the bottom of main body. Please do not lean, lift, or move while machine is in operation.

Control Panel

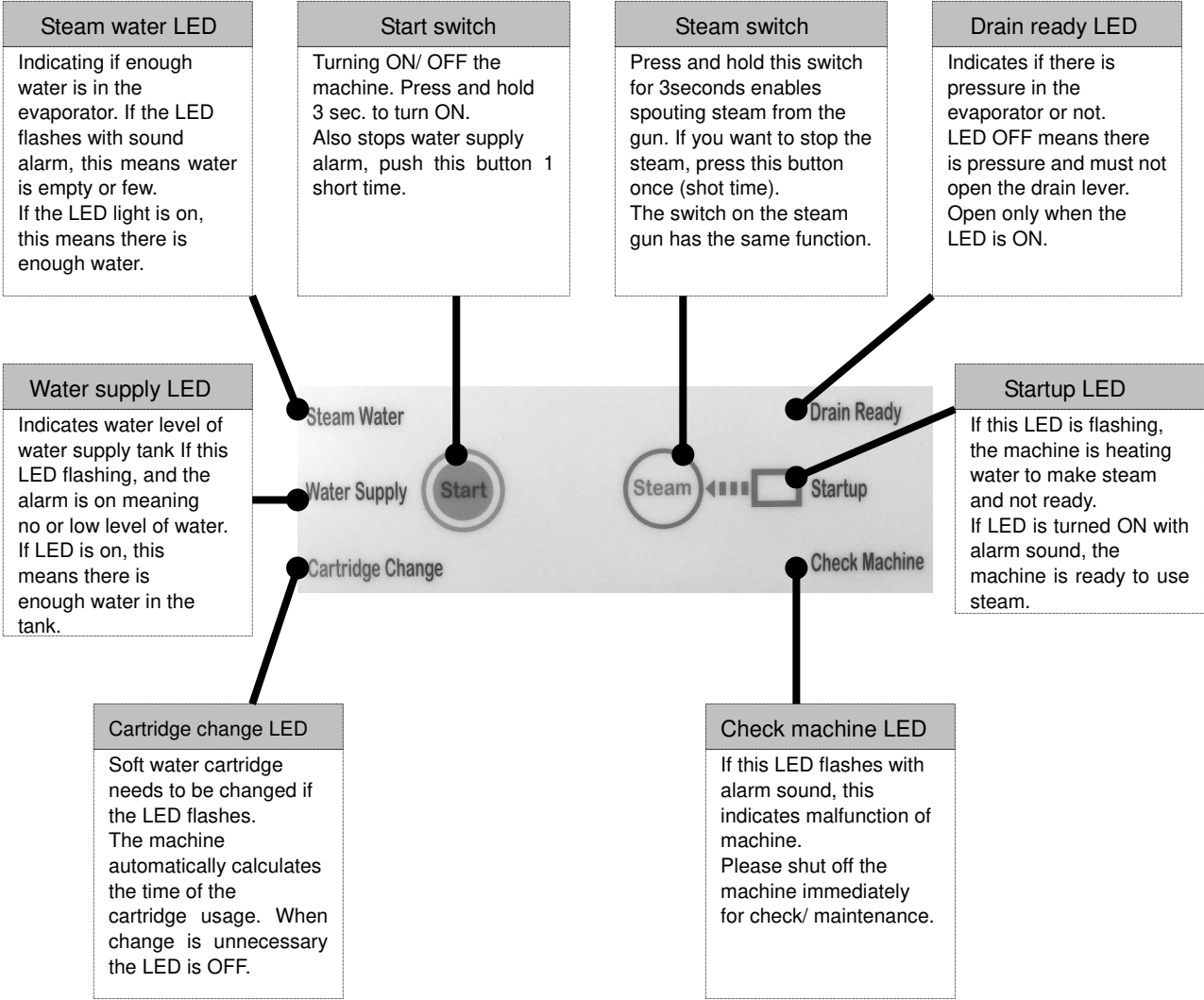

5. Preparation for usage

Preparation of machine (For the first time usage)

- ① Set steamer body on the wagon.
(As the picture shown right)
Put 2 drain hoses into drain bottle.

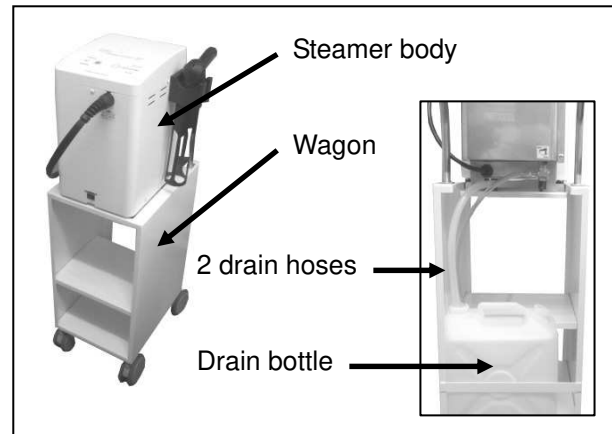

CAUTION

Machine fall detector is equipped on the bottom of main body.
Please set the machine horizontally. If the detector is on, you can not turn on the machine

- ② Slide the 2 convex parts of nozzle holder into the 2 slits on the side of steamer body.
*Slide in and push down to secure the installation.

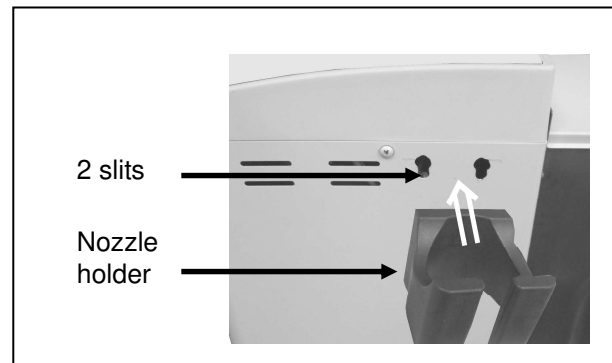

- ③ Open the supply tank lid and take out the inner tank.

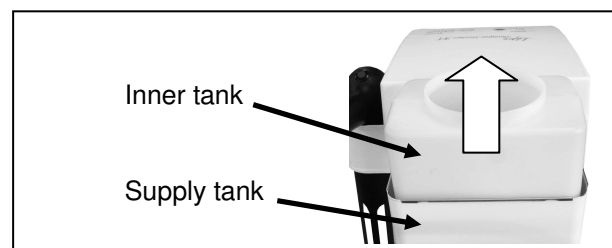

- ④ Place soft water cartridge into inner tank.
Push the cartridge into output direction.
* Make sure the O-ring of soft water cartridge is in straight line.
If the gasket is not straight, please pull out the cartridge and insert again.

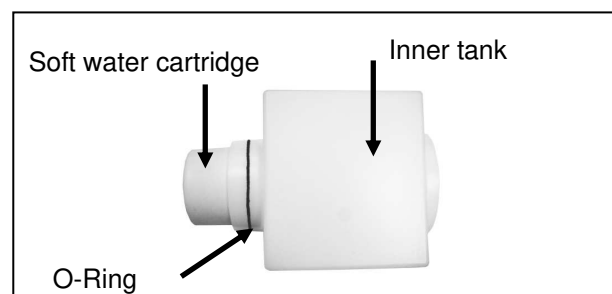

- ⑤ After installing the soft water cartridge, put the inner tank back to supply tank.

- ⑥ Check if drain lever for supply tank is closed. (Lever should be on close side)

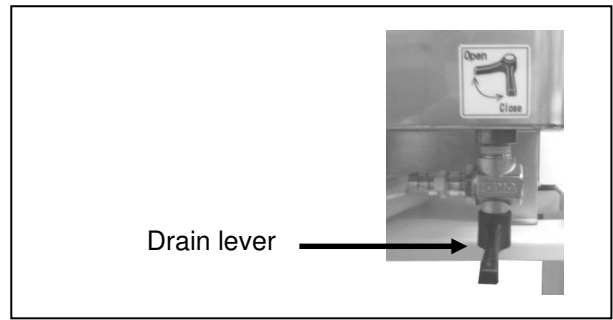



- ⑦ Supply water to the inner tank inside of supply tank. This water will go through soft water cartridge and will be collected to supply tank. After filling the water, put the lid.

Max. capacity of the tank is 4.5L.

*Water goes through soft water cartridge slowly.

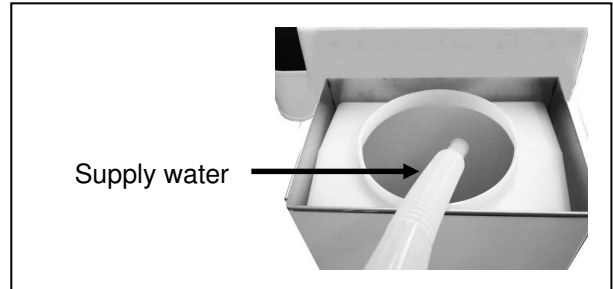
During this time water will remain in the inner tank.



 CAUTION	Use tap water. Do not use distilled or pure water, this cause malfunction on the water level sensor and other parts.
--	--

- ⑧ Check if the drain lever for evaporator is closed. (lever should be on close side)
Plug in the power cord to AC supply. Turn on the main power switch. (turn to I side)

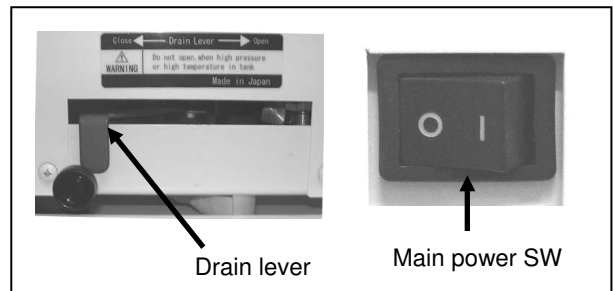

 WARNING	WARNING -This machine is rated AC220V. Please plug this machine to rated power outlet. Also this machine must be connected to grand. Wrong connection will cause electronic shock or fire.
--	---

- ⑨ Press and hold the start switch on control panel for 3 seconds to turn the machine to driving mode and the pump automatically conveys water from supply tank to evaporator and heats water.

*While heating water, startup LED flashes.

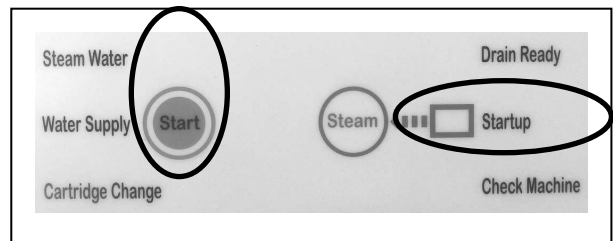

- ⑩ If the startup LED turns from flash to ON, steam is ready to use.

*When the LED is turning flash to ON, alarm will sound for 1 second.

From the second time usage (Regular preparation)

From the second time usage, you can proceed preparation as below. You can repeat this procedure every morning before using the steamer.

- ① Plug in the power cord to power outlet. Then turn the main power switch on. (to I side)

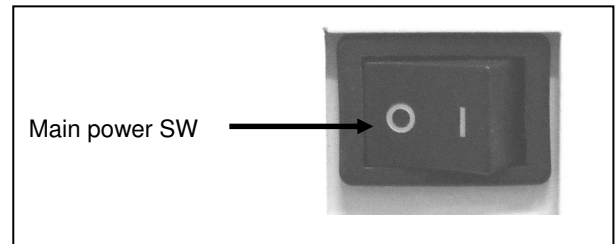

WARNING

WARNING -This machine is rated AC220V. Please plug this machine to rated power outlet. Also this machine must be connected to ground. Wrong connection will cause electronic shock or fire.

- ② Make sure drain ready LED on the control panel is ON.
*If drain ready LED is OFF, there is pressured steam inside of evaporator. Do not Proceed following steps.

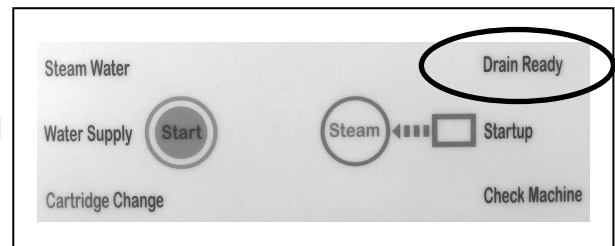

If the LED is off, follow: **7. Shutting down the machine**, Steps 2 ①

- ③ Put 2 drain hoses into drain bottle.
Turn the knob of drain lever of the evaporator tank to the left for loosening. (The knob locks the lever, and you can only move this knob to limited area.)
Open drain lever to open direction.

*Max quantity of drain: 1.5L.

*Machine does not drain water if the machine is power OFF.

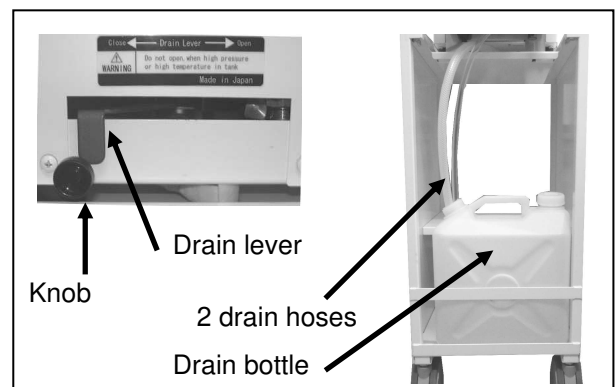

WARNING

Do not open the drain lever while drain ready LED is OFF. There is still pressured steam inside of evaporator. Pressured steam will sprout from drain hose. You might burn yourself.

④ After all the water is drained, close drain lever (to close direction). Move the knob to the right-hand side, and this locks drain lever. Dump the drained water in drain bottle.

⑤ Check if there is water inside of supply tank.
If the water is low, add water into inner tank.
This water will go through soft water cartridge
and will be collected to supply tank.
After filling the water, put lid for the tank.

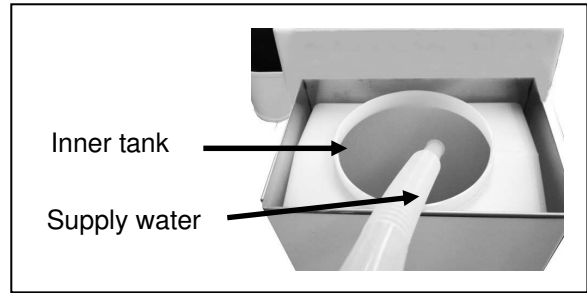

*Water goes through soft water cartridge slowly.
During this time water will remain in the inner tank.

 CAUTION	Use tap water. Do not use distilled or pure water, this cause malfunction on the water level sensor and other parts.
--	--

⑥ Press and hold the start switch on control panel for 3 seconds to turn the machine to driving mode and the pump automatically conveys water from supply tank to evaporator and heats water.

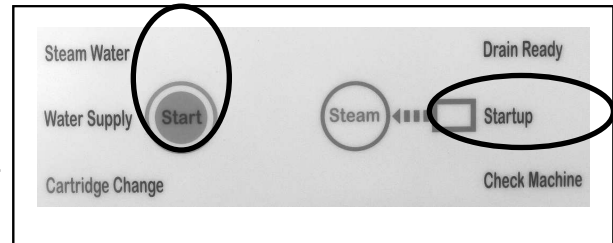

*While heating water, startup LED flashes.

⑦ If the startup LED turns from flash to ON, steam is ready to use.

*When the LED is turning flash to ON, alarm will sound for 1 second.

6. Steam Usage Procedures

For the steam shampoo instruction, please retrieve separately stated book.

Please follow those steps below to operate steam.

① Point the nozzle to safe place (for example a towel is good idea), press and hold the steam switch on the steam gun for 3 seconds.
The gun spouts steam from the nozzle.
To turn off, press the steam switch once (for short time).

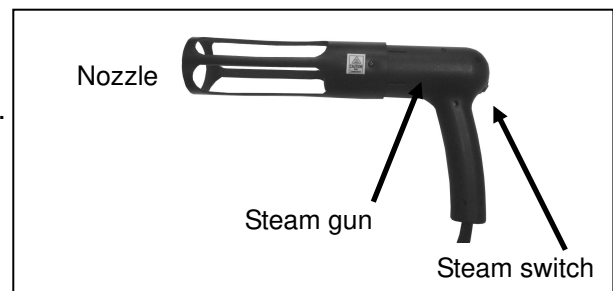

You can also operate this with steam switch on control panel.

*When steam starts, steam consists many water. Use towel to avoid water from dropping.

*When steam starts, the steam consists many air, and steam sometime is weak, but this is fine. Wait few moments.

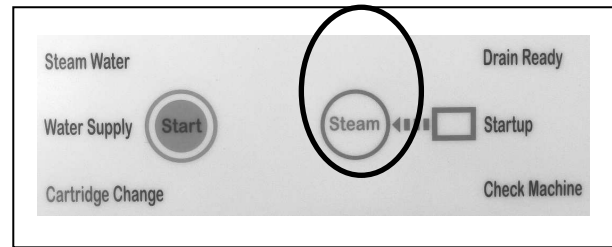

② Apply steam to hair.

You must keep the distance between hair and the nozzle for 10cm (3 inches).

*Must not apply steam inside of hair cap or similar kind of covers. This can dangerously heat up the inside covers.

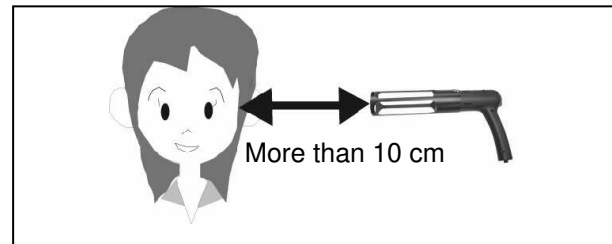

	WARNING	Operator must keep the distance between steam gun and hair. There is possibility of burns.
--	----------------	--

③ If you want to stop steam, press the steam switch on steam gun for once.

*You can push either steam switch on steam gun or the steam switch on the control panel for pushing one time.

④ If the water supply LED flashes with alarm sound while using, this means supply tank needs to be refill.

Add water to the water supply tank.

*Push start switch once (short push) will stop the alarm. Water supply LED turns on to flashing after filling water.

*Even if the water in supply tank is empty, you can use steam for about 10 minutes.

However, early water supply is necessary because if using the steam over 10 minutes, steam water LED will flash, and the machine shuts heater off automatically.

This requires re-start.



7. Shutting down the machine

After use, please follow 3 steps to shut down the machine.

1. Shutting down without draining water from evaporator tank and supply tank.

You have to drain water from evaporator in next day. The **1.** is recommended to shut down.

*Re-filling water without draining water from evaporator create water scale inside of evaporator. This leads malfunctions of the machine. You must drain the water from the evaporator by next day.

2. Draining water from evaporator right after usage.

Draining water from evaporator but keeping supply tank water.

3. Draining both evaporator and water supply tank right after usage.

1. Shutting down without draining water from evaporator tank and supply tank.

- ① Turn off the main power switch. (to O side)
- ② Unplug electronic supply code from outlet.
- ③ Those steps above are all for the day.

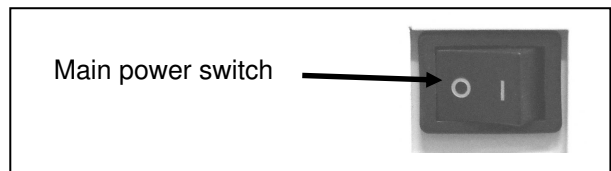

Next day: Drain water from evaporator by following steps.

- ④ Turn on main power switch (to I side) after plug in the power code to outlet.
- ⑤ Make sure drain ready LED is lighting on.

(If the LED is OFF: follow steps **2. Draining water from evaporator right after usage.** of

7. Shutting down machine

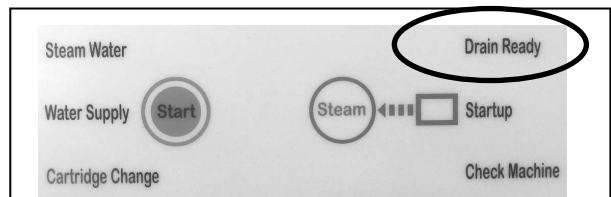

- ⑥ Put 2 drain hoses into drain bottle.

*Max. Capacity of drain: 1.5L

*You must turn on the main power switch ON to drain.

Turn the knob of drain lever of the evaporator tank to the left for loosening. (The knob locks the lever, and you can only move this knob to limited area.) Open drain lever to open direction.

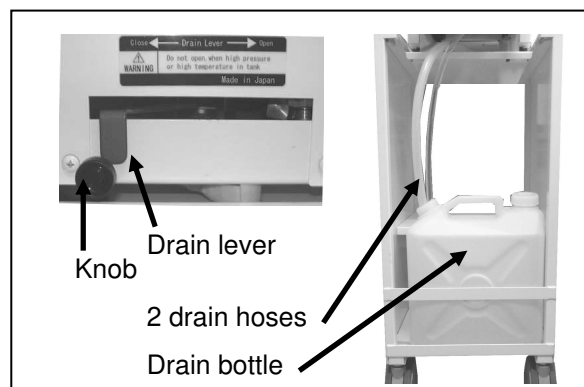

After all the water is drained, close drain lever (to close direction). Move the knob to the right-hand side, and this locks drain lever. Dump the drained water in drain bottle.



WARNING

Do not operate draining while drain ready LED is OFF. There is pressured hot steam inside of evaporator tank. There is possibility of burns steam spouts from drain hose.

- ⑦ If you are using steam, please retrieve procedures in “From the second time usage (Regular preparation)” of 5. Preparation for usage.

If you are not using steam, please turn off main power switch, and take out the power code from power outlet.

2. Draining water from evaporator right after usage.

Following steps is proceeded when power code is connected to power outlet, and main power switch is ON.

 <p>WARNING</p>	<p>Do not open the drain lever right after usage of steam. There is still pressured steam inside of evaporator. Pressured steam will sprout from drain hose. There is a risk of burns.</p>
---	--

- ① Check if the drain ready LED on the control panel is lighting on. If the LED is OFF, please follow below ② to ③ steps to release pressured steam.

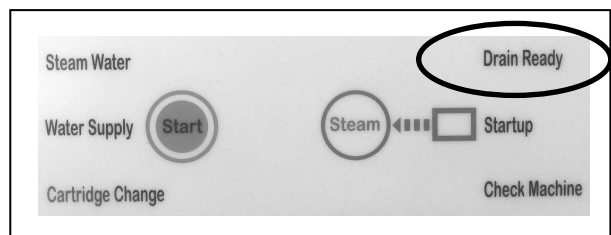

- ② Turn main power switch off. (to O side)
Turn main power switch on (to I side) while holding the start switch.
*This turns machine in maintenance mode.
During the maintenance mode, start switch LED flashes.

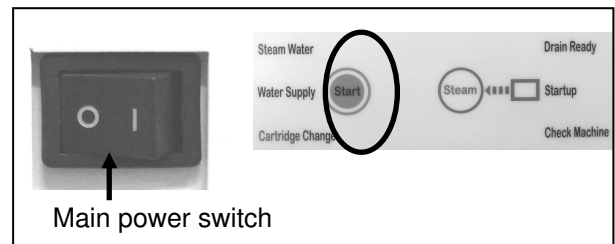

- ③ Point the nozzle to safe place (For example a towel is good idea), press and hold the steam switch on the steam gun for 3 seconds. The gun spouts steam from the nozzle. This releases pressured steam from evaporator.
When drain ready LED is ON, this is the end of releasing pressure from evaporator.

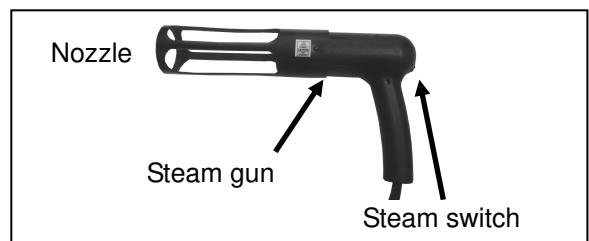

*Releasing pressured steam takes about 10 minutes and drain ready LED switches on a light.

 <p>WARNING</p>	<p>Do not point steam gun nozzle to human body or any parts of body but towels or safe objects. There is a risk of burns.</p>
---	---

- ④ Turn main power switch off, then turn main power switch on again.
*Machine returns to regular operation mode from maintenance mode.
*Steam switch returns to steam off mode automatically.

⑤ Put 2 drain hoses into drain bottle.

Turn the knob of drain lever of the evaporator tank to the open direction. This starts draining. After draining all the water, close the drain lever. Turn the knob and lock the drain lever. Dump the drained water in drain bottle.

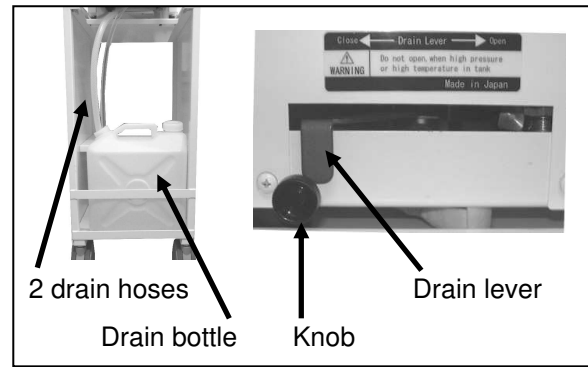

*Do not push start switch while the drain lever is loosened. This turns on alarm and does not start.

*Must turn on main power switch while draining.



WARNING

Extremely hot water will be drained if you drain the water right after usage of the machine. Please use anti-heat drain vessel. Do not touch drained hot water. There is a risk of burns.

⑥ Turn main power switch off and unplug the power cord from power outlet.

3. Draining both evaporator and water supply tank right after usage.

① Follow steps ① to ⑥ of the **2. Drain water from evaporator right after usage.**

② Put 2 drain hoses into drain bottle. Open the drain lever of supply tank. (to the open direction) This starts draining.

*Max. capacity of the supply tank is 4.5L.

Drain water in the drain bottle prior to draining supply tank.

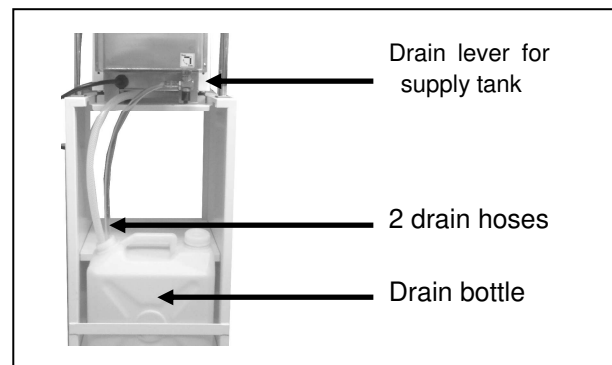

③ Close drain lever of supply tank after draining all water.



CAUTION

Must drain both waters from supply tank and evaporator tank. before storage over 7 days. Water can rot over the time.

If you are storing the machine over 7 days, please take out the soft water cartridge and seal into plastic bag to avoid air exposure. Do not dry soft water cartridge completely. This will cause performance drop.

8. Maintenance and inspection

(1) Daily maintenance

- Remove dirt, dust, and hair on the machine body.
- Remove contamination out of supply tank.
- Remove dirt, dust, and hair from steam gun.

(2) Replace soft water cartridge every 6 months to year.

The soft water cartridge is equipped in supply tank. The water softener will lose effectiveness over changing certain amount of water. The machine counts the time of usage, and will inform you to when it is necessary to replace the soft water cartridge with flashing cartridge change LED on control panel. Please follow steps below to change soft water cartridge. You can purchase soft water cartridge at your dealer.

- ① Turn main power switch off, unplug the power code from the outlet.
Take out the inner tank from supply tank.
*Prepare bucket or bowl to receive the dropping water from inner tank.

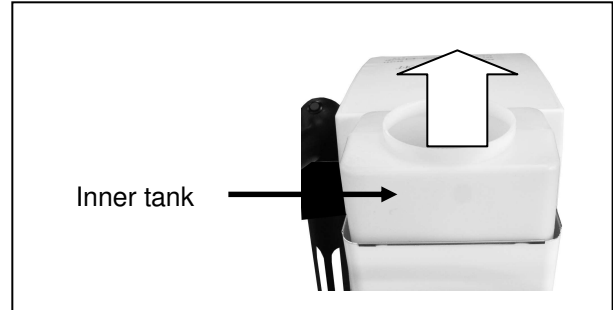

- ② Push the bottom of soft water cartridge, and push into inner tank.
Take out the cartridge from inner tank.
*Dispose used soft water cartridge depends on regulation.

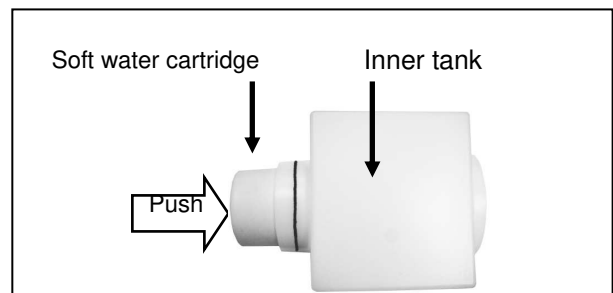

- ③ Install new soft water cartridge pushing into inner tank outlet hole.
* Make sure the O-ring of soft water cartridge is in straight line. If the gasket is not straight, please pull out the cartridge and insert again to make it straight.

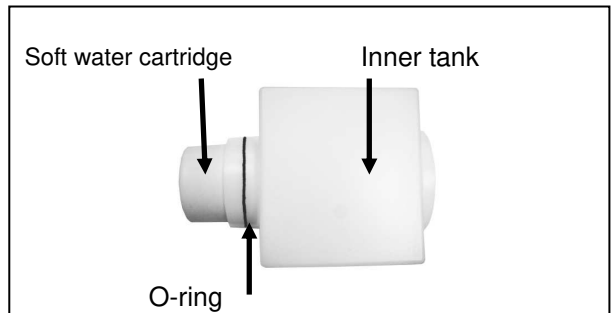

- ④ Put inner tank back to supply tank.
⑤ Plug in the power code to power outlet.
⑥ With holding start switch on, turn the main power switch on.
*This turns machine into maintenance mode.
Start switch LED flashes during the maintenance mode.

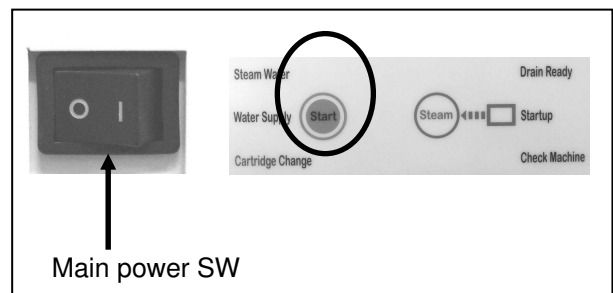

- ⑦ Push and hold start switch for 7 seconds. The alarm informs you that the soft water cartridge change time reset is done.

- ⑧ Turn main power switch off, then turn main power switch on again.
* If the resetting is complete, cartridge change LED is OFF.

- ⑨ If you see any contamination inside of supply tank and inner tank, turn off main power switch, then disconnect power cord from power outlet. Drain water from supply tank following ② and ③ of 3. **Draining both evaporator and water supply tank right after usage.** of

7. Shutting down the machine

Clean inside of supply tank and Inner tank with clean cloth.



WARNING

Do not use any detergent or solvent for cleaning supply tank and inner tank. Use clean cloth to wipe. Detergents and solvents will cause machine malfunction.

(3) Annual maintenance (Cleaning with steamer tank cleaning liquid)

Scale deposits inside of evaporator tank and piping after long time usage. Remove scale of evaporator tank and piping every year with using designated steamer tank cleaning liquid by following steps below.

- ① Drain water from evaporator tank following ① to ⑥ in the **2. Draining water from evaporator right after usage** of **7. Shutting down the machine**.

- ② Take out the inner tank from supply tank.

*Prepare bucket or bowl to receive the dropping water from inner tank.

*Inner tank is not necessary while cleaning.

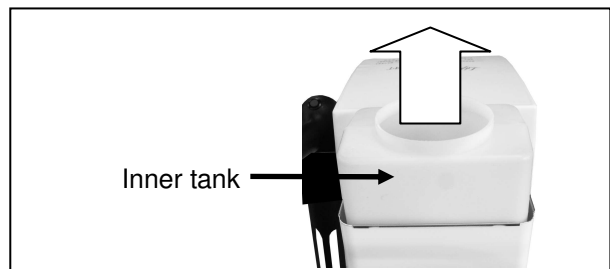

- ③ Put 2 drain hoses into drain bottle. Loosen drain lever to open direction. (to OPEN)

*Supply tank holds 4.5L for the max. Prepare a vessel or bucket with over the quantity. After draining all the water from the supply tank, close the drain lever. (to CLOSE)

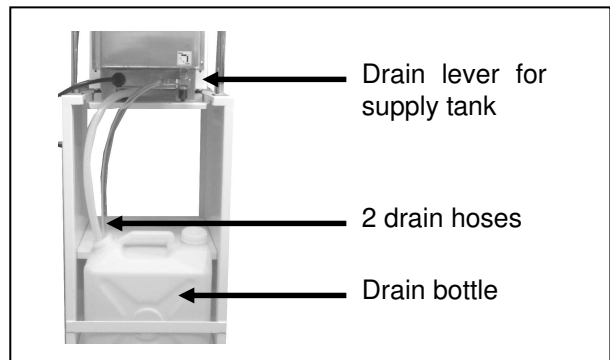

- ④ Fill 3L of water to supply tank.

Put 1 whole bottle of designated steamer tank cleaner. Put supply tank lid.

*Do not use commercial cleaning agent. This may cause erosion in piping.

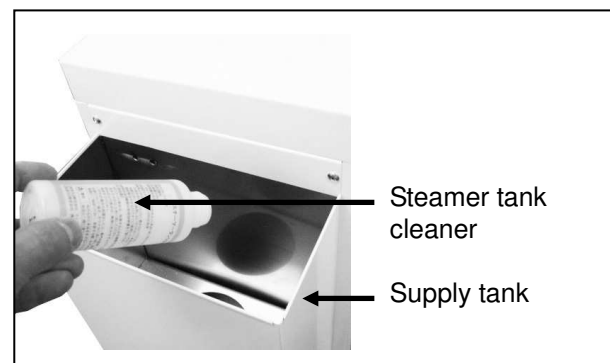

- ⑤ Turn main power switch on after plug in the power cord to outlet.
Push and hold start switch on control panel for 3 seconds and select WET mode.

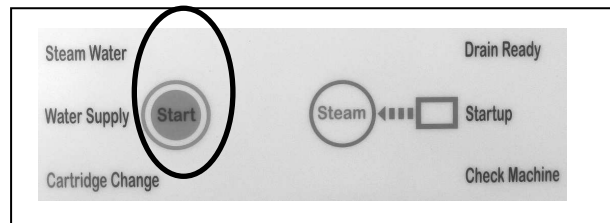

*Either DRY or WET mode is fine.

*This is the same as the normal operation, so there will be pressured steam inside of the evaporator.

Let the machine drive for 1 hour. After 1 hour, turn OFF with pushing start switch.

* Stop the machine less than 2 hours. Driving too long time with cleaning agent may cause erosion in piping.

- ⑥ Drain water from evaporator following ① to ⑥ in the **2. Draining water from evaporator right after usage** of **7. Shutting down the machine**.

- ⑦ Drain water from supply tank following ③ above.

- ⑧ Fill 3L of water to supply tank.

*The procedures below are to wash out the cleaner from evaporator and supply tank.

- ⑨ Following the ⑤ above, re-start machine.

When water pump sound is stopped, turn off the start switch.

*You don't have to leave the machine on 1 hour as written in ⑤ above.

- ⑩ Drain water from evaporator following ① to ⑥ in the **2. Draining water from evaporator right after usage** of **7. Shutting down the machine**.

- ⑪ Following the step ③ above, drain water from supply tank.

- ⑫ Clean the inside of supply tank and inner tank with clean cloth.



WARNING

Do not use any detergent or solvent for cleaning supply tank and inner tank. Use clean cloth to wipe. Detergents and solvents will cause machine malfunction.

- ⑬ Put inner tank back to supply tank.

This is all for annual maintenance with using designated steamer tank cleaning liquid.

9. Troubleshooting

Symptoms	Probable Cause	Problem Solution
Machine does not turn on. All LEDs on the control panel do not turn on.	Power code is not connected to power outlet.	Connect power code.
	Main power switch is OFF.	Turn main power switch on.
	Machine fall detector is activated.	Set the machine to flat place.
	Transmitter fail	Require repair at factory.
	Control panel malfunction	Require repair at factory.
Start switch does not start the machine	Drain lever for evaporator is open.	Close the drain lever.
	Do not push for 3 second.	Push and hold start switch appropriately.
	No water in supply tank.	Fill water to supply tank.
	Machine is in maintenance mode.	Turn off the main power switch and then turn on the switch.
	Check machine LED is flashing	Require repair at factory.
	Control panel malfunction	Require repair at factory.
Drain ready LED is always off or on.	Temperature sensor malfunction	Require repair at factory.
Check machine LED is flashing	There is any trouble in evaporator tank or pump.	Require repair at factory.
Steam does not come out from the nozzle	Did not push and hold the steam switch.	Press and hold the switch for 3 seconds.
	Steam is still in preparation stage (Startup LED is flashing)	Wait for the Startup LED turns on.
	Tank heater malfunction	Require repair at factory.
	Steam switch malfunction	Require repair at factory.
	Steam solenoid malfunction	Require repair at factory.

10. Specification

Name of this product	Type: SPH(S) Lapre Shampoo Steamer AT
Rated Voltage and Frequency	1φ AC220V、50Hz/60Hz
Rated Max. Consumption Rate	1250W
Safety Features	Evaporator tank temperature sensor Forced release function for abnormal pressure in evaporator Machine fall detector
Dimensions	Steamer main body: W220mm×D380mm×H370mm (without steam tube clamp)
Weight	Steamer main body :12Kg (without water)

- Download a instruction manual of **Type:SPH(S) Lapre Shampoo Steamer AT** from <https://www.tipros.co.jp/support>